

Adroit 007 / 007C / 007S

Stationary Shotcrete Pumps



Adroit 007C

Adroit 007 series shotcrete machines are suitable for manual operation and they absolutely do not generate any dust during application. Adroit 007 series, have 8 m³/h concrete pumping capacity. Easy-to-operate Adroit 007 series are ideal for narrow profiled tunnels where truck mounted equipments and 4x4 vehicles are not able to access as well as being low rebound machinery with low cost of operation and maintenance. By virtue of all of these reasons Adroit 007 series is one of the most preferred shotcrete machines in the construction industry.

GENERAL SPECIFICATIONS

- > Valf groups, electrical panel, motors and pumps are sheltered by compact modular system
- > Stabilizer cylinder and valve group
- > Hydraulic oil cooler
- > Eyebolts and towing hooks to use in loading and transporting the machine
- > Led working lights

DIMENSIONS AND WEIGHT

	Adroit 007	Adroit 007C	Adroit 007S
> Length	3300 mm	4950 mm	2700 mm
> Width	1350 mm	1560 mm	1000 mm
> Height	1800 mm	1900 mm	1600 mm
> Weight	1540 kg	3200 kg	1480 kg

CONCRETE PUMP

- > Theoretical max. capacity of pumping shotcrete : 8 m³/h
- > Pumping pressure : max. 60 bar
- > Hydraulic pressure : max. 250 bar
- > Aggregate size : max. 16 mm
- > Adroit shotcrete machines are able to pump all type of fibers
- > Hydraulically driven hopper vibrator

ACCELERATOR SYSTEM

- > Electrically driven accelerator peristaltic pump
- > Dosing rate : max. 0 to 20 L/min
- > Pumping pressure : max. 15 bar
- > Accelerator tank : 600 L
- > Dosing rate can be controlled manually, flow rate (L/min) and dosing percentage (%) readable on the display

COMPRESSOR

- For only Adroit 007C;
- > Electrically operated screw compressor
- > Capacity : 6 m³/min.
- > Pressure : 8 bar
- > Electric motor : 37 kW

TIRES

- > 7.50 - 16 for only wheeled type

BRAKE SYSTEM

- > Mechanical hand brake for only wheeled type

HYDRAULIC SYSTEM

- > Tank capacity 140 L
- > Hydraulic filtration, fluid temperature and tank fluid level sensing and warning system

HIGH VOLTAGE ELECTRICAL SYSTEM

- > Waterproof control panel
- > 380 V, 50 Hz. cable type 3 x 380 / 50
- > Power pack : 22 kW electrical motor

OPTIONAL COMPONENTS

- > Electrically driven hopper vibrator
- > Automatic lubrication system

Adroit 007

Adroit 007S

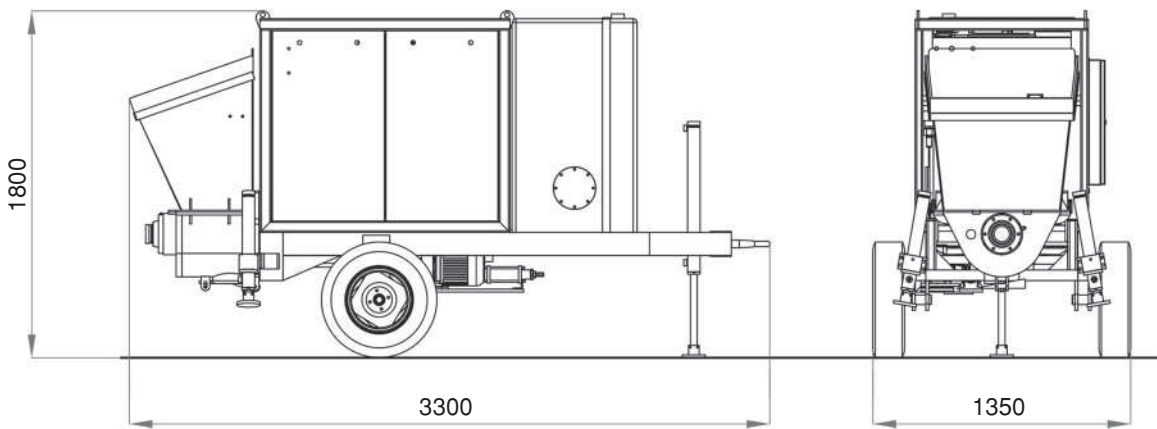

Adroit 007

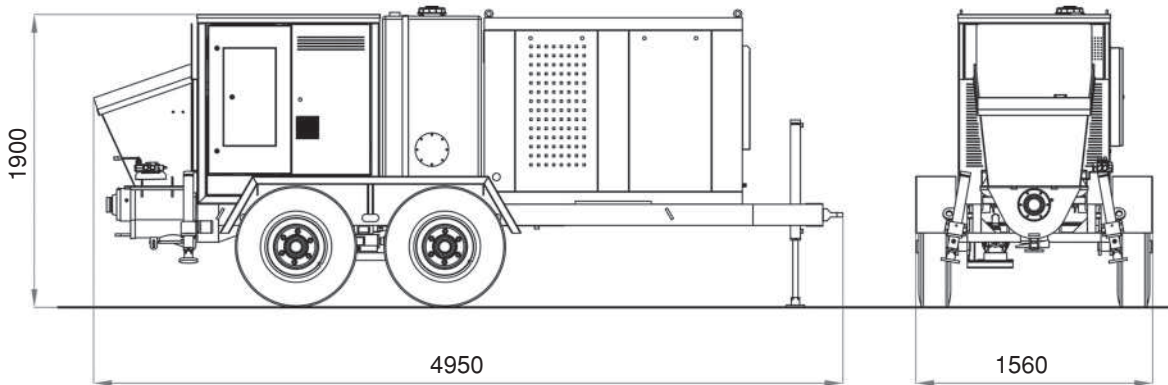

Adroit 007C

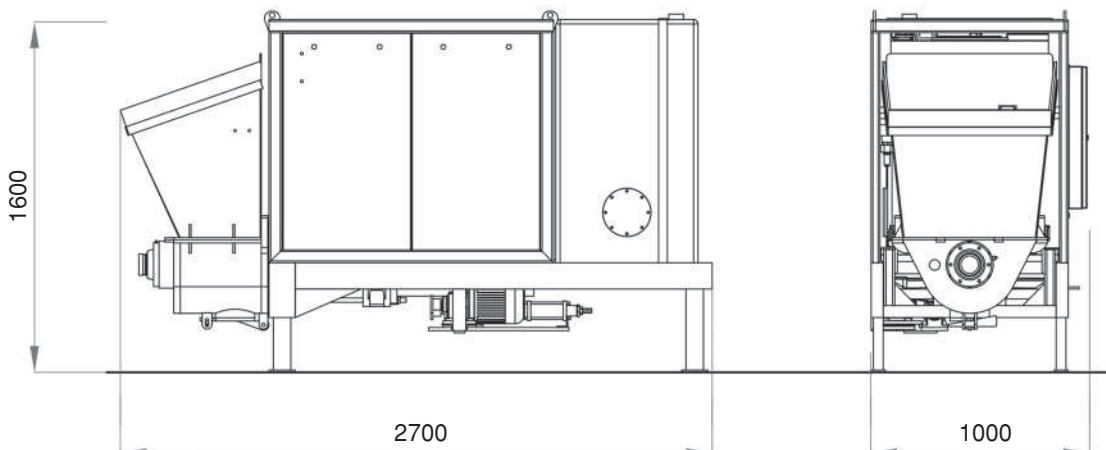

Adroit 007S