

Adroit 412T

Crawler Shotcrete Distributor



Adroit 412T is designed to perform wet and dry shotcrete application fast and efficiently on rough terrains, at shaft applications, in stairs tunnels and the parts of underground mines that are difficult to access and on highly inclined slopes where truck-mounted, 4x4 robot and stationary shotcrete pumps and concrete mixers cannot reach. It is an ideal solution for ground applications and earthquake retrofitting works. Adroit 412T can make 360° shotcreting, up to 16 m diameter shaft applications. Thanks to its track crawler drive system it can be easily positioned on the application sites where other vehicles cannot reach. Platform angle can be adjusted to a suitable position with platform cylinder for driving and working. The shotcrete that is conveyed to Adroit 412T through concrete pipe line and by Adroit shotcrete pumps can be easily applied by means of a cable / radio remote control.

GENERAL SPECIFICATIONS

- > Telescopic boom system
- > Nozzle rotation group
- > Cable remote control
- > Platform lifting cylinder
- > Stabilizer cylinder and valve group
- > Eyebolts and towing hooks to use in loading and transporting the machine
- > Hydraulic oil cooler

DIMENSIONS AND WEIGHT

- > Length 2800 mm
- > Width 1800 mm
- > Height 2200 mm
- > Weight 4500 kg

ACCELERATOR SYSTEM

- > Electrically driven accelerator peristaltic pump
- > Dosing rate : max. 0 to 20 L/min.
- > Pumping pressure : max. 15 bar
- > Accelerator tank : 600 L
- > Dosing rate can be controlled manually, flow rate (L/min) and dosing percentage (%) readable on the display.

ENGINE

- > Perkins 404D - 22 36 kW@2800 rpm
- Diesel engine EU Stage 3A

FUEL SYSTEM

- > Tank capacity 120 L
- > Fuel hose securely fixed and isolated from the hot surfaces

HYDRAULIC SYSTEM

- > Tank capacity 160 L
- > Hydraulic filtration, fluid temperature and tank fluid level sensing and warning system

HIGH VOLTAGE ELECTRICAL SYSTEM

- > Waterproof control panel
- > 380 V, 50 Hz. cable type 3 x 380 / 50
- > Power pack : 7,5 kW electrical motor
- > Cable reel

OPTIONAL COMPONENTS

- > Radio remote control
- > Catalytic converter with diesel particle filter
- > EU Stage 5 diesel engine

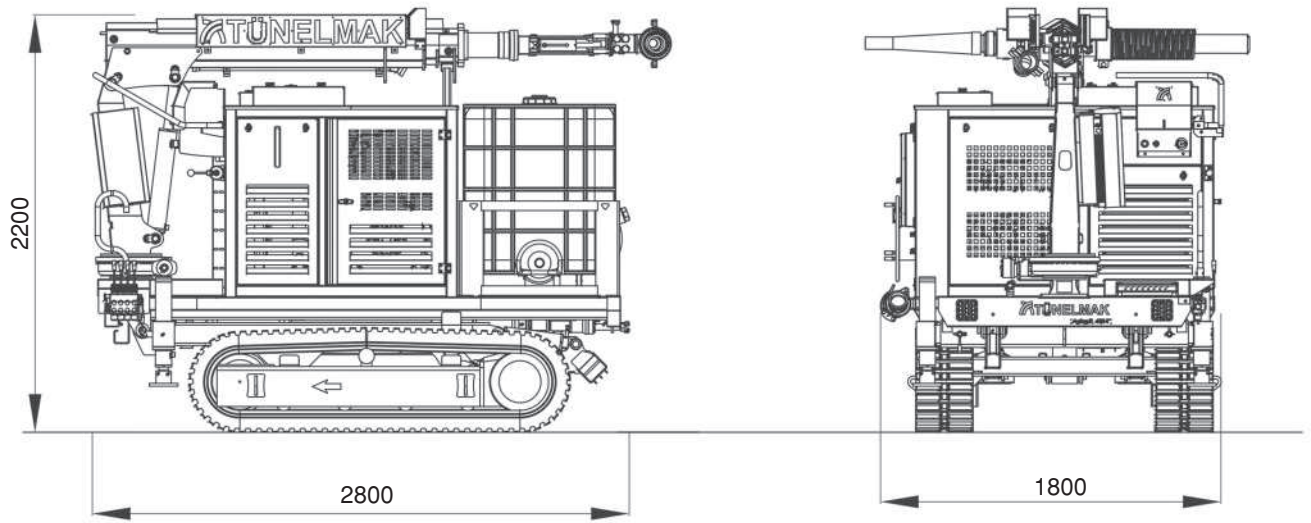

Operation Diagram

