

# Adroit 605

## 4x4 Underground Personnel And Load Carrying Vehicle



Adroit 605 which is ideal for underground transportation is designed to carry personnel and load at the same time. Level 2 certified FOPS - ROPS cabin is fully equipped with suspended seats, air conditioner and reversing audible and visual warning system. It provides perfect mobility for the workers in underground mines and helps to carry the material up to 250 kg and 5 personnel. Adroit 605 has automatic transmission drive system which offers front wheel control, four wheel steering and crab steering.

### GENERAL SPECIFICATIONS

- > Led control panel showing fault, warning and driving info
- > Front and rear parking sensor
- > Front and rear projectors
- > Rear view camera
- > Reversing audible and visual warning system
- > Eyebolts and towing hooks to use in loading and transporting the machine
- > 12 VDC output inside the cabin for vehicle radio
- > 4 kg fire extinguisher

### DIMENSIONS AND WEIGHT

- |          |         |          |         |
|----------|---------|----------|---------|
| > Length | 5400 mm | > Height | 2200 mm |
| > Width  | 2150 mm | > Weight | 4250 kg |

### OPERATOR CABIN

- > FOPS - ROPS level 2 certified closed operator cabin
- > Air conditioner inside the cabin
- > Laminated and tempered glasses
- > Heated glasses and side-view mirrors
- > Washable cabin upholstery
- > 3 points contact, non-slippery stairs
- > Emergency stop button inside the cabin
- > Operator seat
  - Suspended
  - Retractable seat belt
  - Sensor that activates the park brakes when the operator stand up

### ENGINE

- > Cummins ISF 2.8 110 kW@3200 rpm Diesel engine Euro Stage 3A
- > Engine / radiator fluid level warning

### EXHAUST SYSTEM

- > Catalytic converter with diesel particle filter

### TRANSMISSION

- > Allison automatic transmission
- > 5 speed forward and 1 speed reverse
- > 4 wheel drive

### AXLE SYSTEM

- > Planetary type Dana 211
- > Solid axle, coil spring suspension

### TIRES

- > 295 / 60 R22,5 size heavy duty tires, suitable for underground work

### PERFORMANCE

- > Max. speed 40 km
- > Fully loaded max. speed in 15% incline : 20 km/h
- > Max. climb gradient 50%

### BRAKE SYSTEM

- > Service brake: Hydraulically powered two circuit oil immersed multidisc brake in both axles
- > Parking brake: S.A.H.R fail safe brake
- > Brake systems test set-up in cabin

### STEERING

- > Four wheel steering, crab steering, front wheel steering

### FUEL SYSTEM

- > Tank capacity 80 L
- > Fuel hose securely fixed and isolated from the hot surfaces

### HYDRAULIC SYSTEM

- > Tank capacity 30 L
- > Hydraulic filtration, fluid temperature and tank fluid level sensing and warning system

### ELECTRICAL SYSTEM

- > Electrical components : IP65 and above protection grade
- > Battery 135 Ah
- > Led lighting lamps illuminating the movement direction
- > Flashing beacon lamps in amber colour
- > Fire - resistant wiring

### OPTIONAL COMPONENTS

- > EU Stage 5 diesel engine
- > Diesel engine fire suppression system

**Adroit 605** 4x4 Underground Personnel And Load Carrying Vehicle  
Dimensions of Vehicle

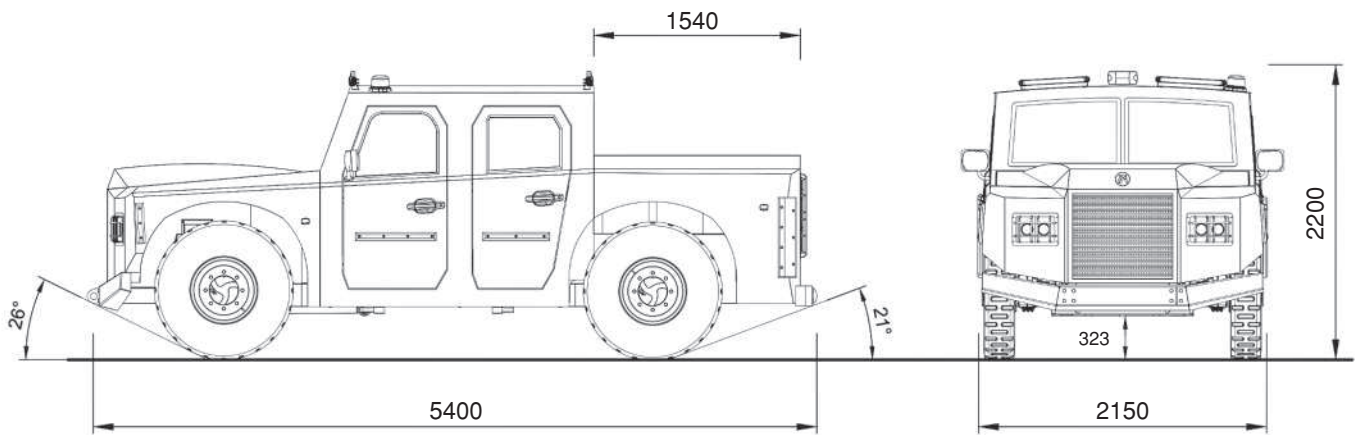

**Climbing Capacity**

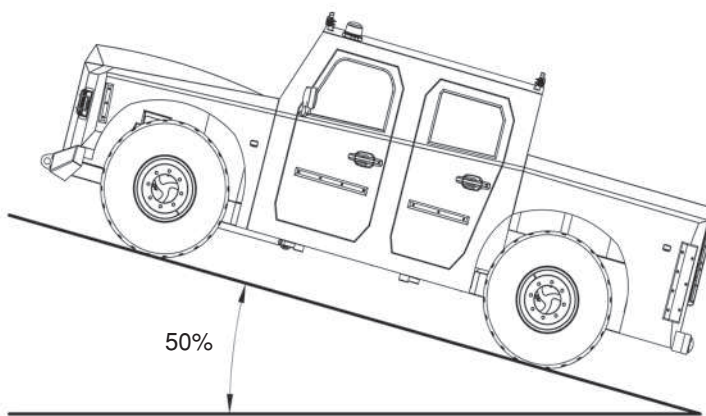

Max. Speed - Max. Power of Climbing  
Adroit 605 with 5-speed automatic transmission system offers long distance drives on flat terrains and have capacity of 50% gradient climbing.

Max. speed 40 km and fully loaded max. speed in 15% incline 20 km/h.

**Turning Radius**

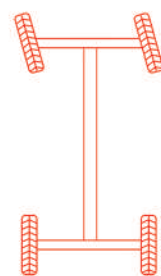
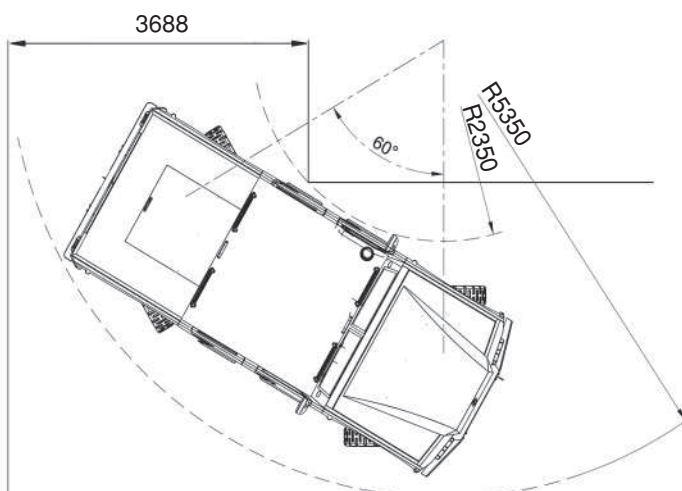

Front Wheel Control

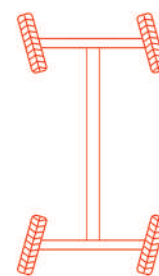

Four Wheel Steering

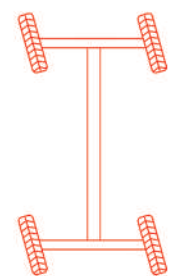

Crab Steering