

Adroit 660AW

4x4 Articulated Multipurpose Chassis



The Adroit 660AW is designed as a multi-purpose chassis that provides innovative solutions for logistics in tunnels and mines. The Adroit 660AW is a mutual carrier of cassettes, each serving a different purpose. Cassettes that a single operator can change in a very short time without assistance can be of various types such as tankers, personnel carriers, platforms and so on. It provides superior maneuverability and driving opportunity with its 4x4 powershift driving system and articulated chassis.

GENERAL SPECIFICATIONS

- > Led control panel showing fault, warning and driving info
- > Rear view camera
- > Reversing audible and visual warning system
- > Handheld fire extinguisher
- > 12VDC output inside the cabin for vehicle radio
- > Eyebolts and towing hooks to use in loading and transporting the machine

DIMENSIONS AND WEIGHT

- | | |
|-----------------------|----------|
| > Length | 8150 mm |
| > Width | 2150 mm |
| > Height | 2490 mm |
| > Weight | 8000 kg |
| > Fully loaded weight | 22000 kg |

CASSETTE OPTIONS

- > Personnel carrying cassette
 - 16 personnel carrying capacity
 - Suspended seats and retractable seat belts
 - Intercom
 - Air conditioner system
- > Watering cassette
 - Tank capacity 3800 L
 - Hose reel and pump compartment
- > Load carrying cassette
 - Carrying capacity 6000 kg
- > Crane cassette
 - Carrying capacity 5000 kg
 - Crane capacity 25 kNm
- > Scissor lift cassette
 - Lifting capacity 1500 kg
- > Anfo charge cassette
- > Lube cassette
- > Mixer cassette
- > Workshop cassette

CASSETTE SHIFTER

- > Lifting and placing mechanism for cassettes
- > Carrying capacity : 14000 kg

OPERATOR CABIN

- > FOPS - ROPS level 2 certified closed operator cabin
- > Air conditioner inside the cabin
- > Laminated and tempered glasses
- > Heated glasses and side-view mirrors.
- > Washable cabin upholstery
- > 3 points contacted, non-slippery stairs
- > Emergency stop button inside the cabin
- > Operator seat
 - Suspended
 - Retractable seat belt
 - Sensor that activates the park brakes when the operator stand up

ENGINE

- > Deutz TCD 2013 L04 2V 129 kW@2300 rpm Diesel engine EU Stage 3A
- > Engine / radiator fluid level warning

EXHAUST SYSTEM

- > Catalytic converter with diesel particle filter

TRANSMISSION

- > Powershift automatic transmission : Dana 24000 series
- > 3 speed forward and 3 speed reverse
- > 4 wheel drive

AXLE SYSTEM

- > Planetary type Dana 123
- > Oscillating front axle $\pm 8^\circ$

TIRES

- > 14.50 - 20 size heavy duty tires, suitable for underground work

PERFORMANCE

- > 1st gear : 6 km/h
- > 2nd gear : 12 km/h
- > 3rd gear : 25 km/h
- > Max. climb gradient 40%

BRAKE SYSTEM

- > Service brake: Hydraulically powered two circuit oil immersed multidisc brake in both axles
- > Parking brake: S.A.H.R fail safe brake.
- > Brake systems test set-up in cabin.
- > Handbrake system on cardan shaft

FUEL SYSTEM

- > Tank capacity 140 L
- > Fuel hose securely fixed and isolated from the hot surfaces

HYDRAULIC SYSTEM

- > Tank capacity 135 L
- > Hydraulic filtration, fluid temperature and tank fluid level sensing and warning system
- > Central pressure control point for system pressure measurement

24VDC ELECTRICAL SYSTEM

- > Electrical components : IP65 and above protection grade
- > Battery 2 x 135 Ah
- > Led lighting lamps illuminating the movement direction
- > Led flashing beacon in amber colour
- > Fire - resistant wiring

OPTIONAL COMPONENTS

- > Side view camera
- > EU Stage 5 diesel engine
- > Diesel engine fire suppression system

Turning Radius

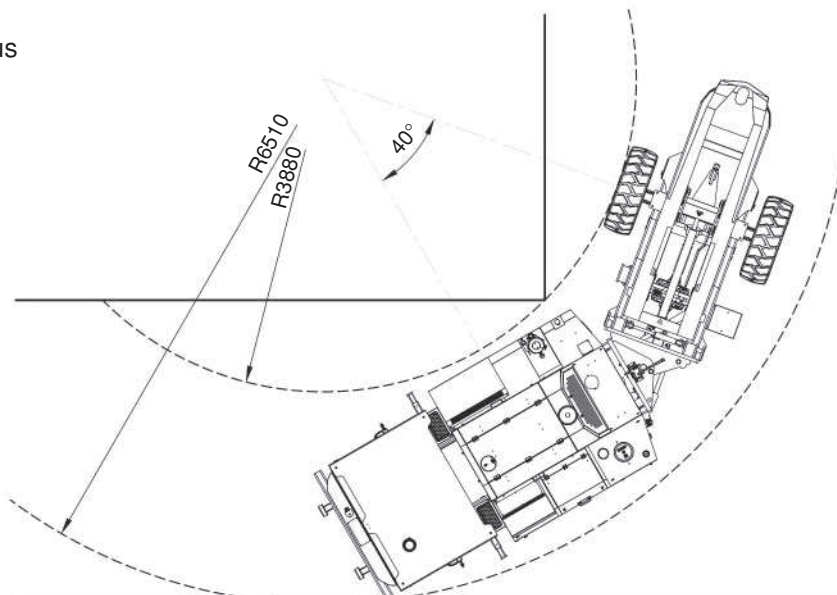

Adroit 660AW 4x4 Articulated Multipurpose Chassis
Dimensions of Vehicle

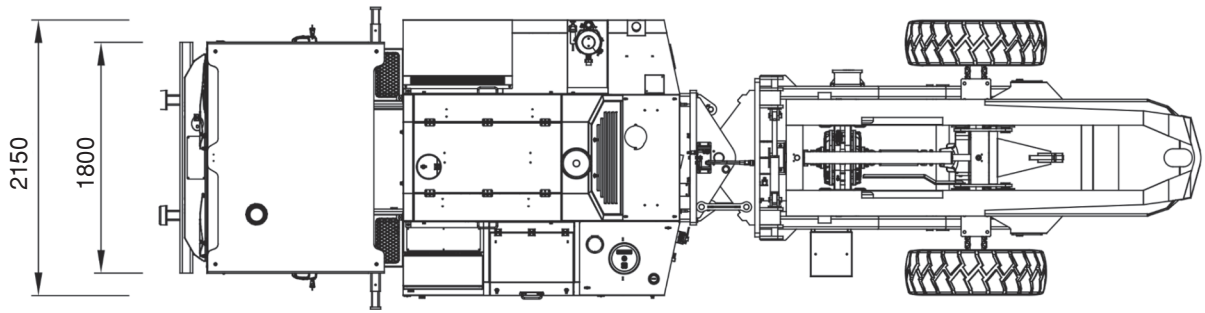
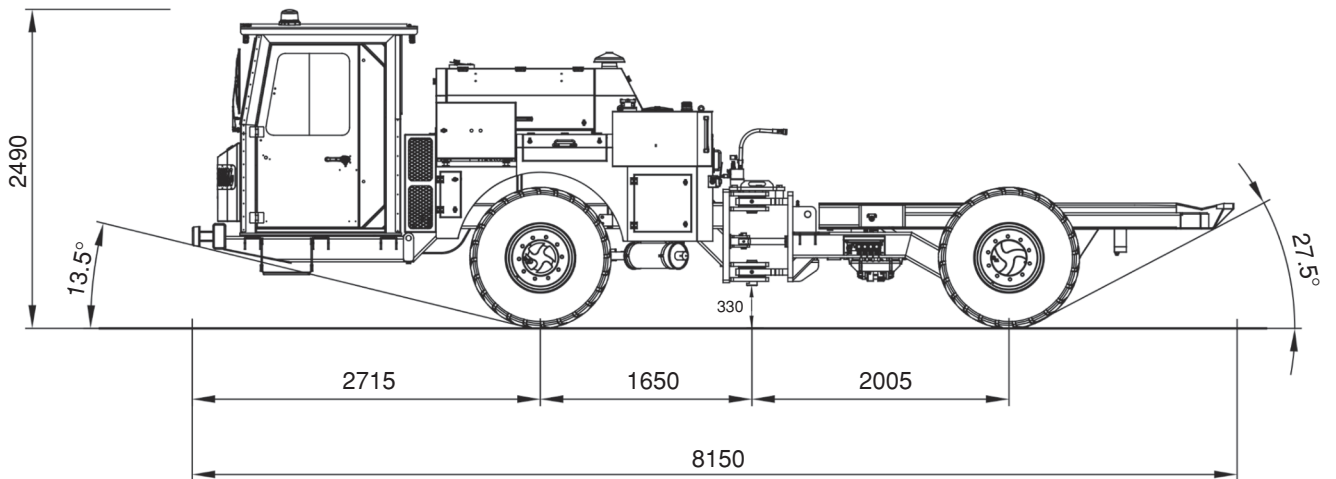

Personnel Carrying Cassette

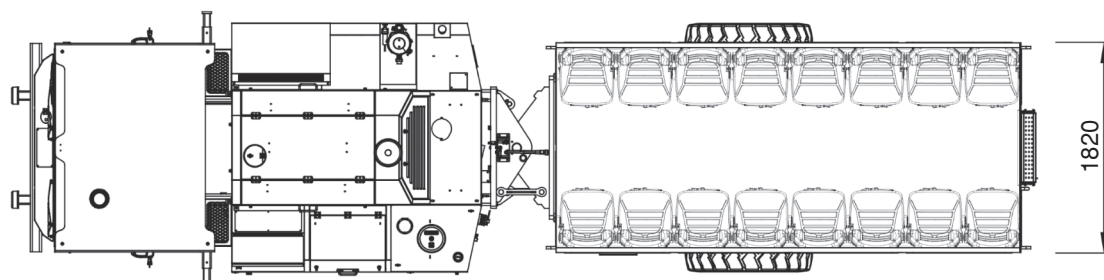
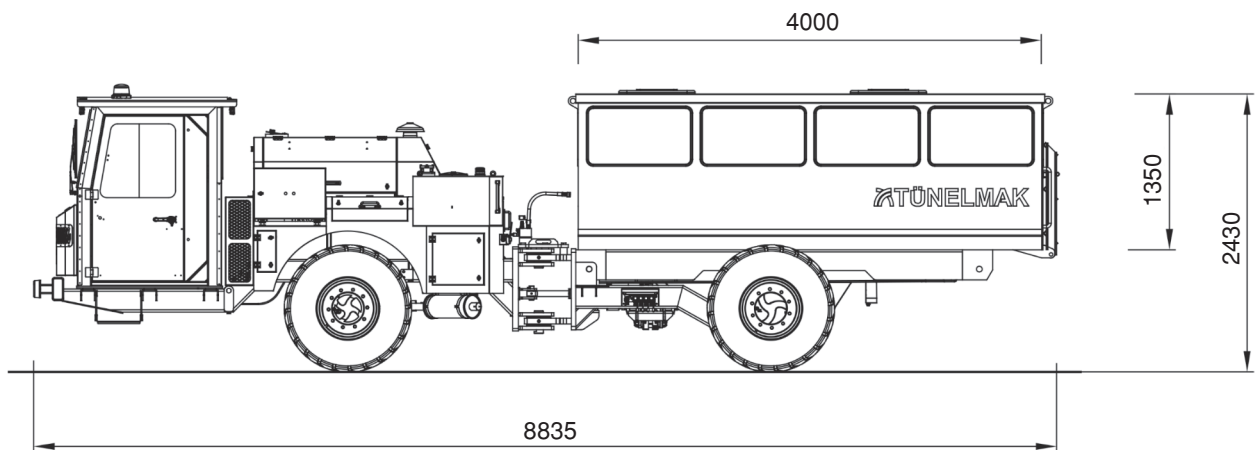

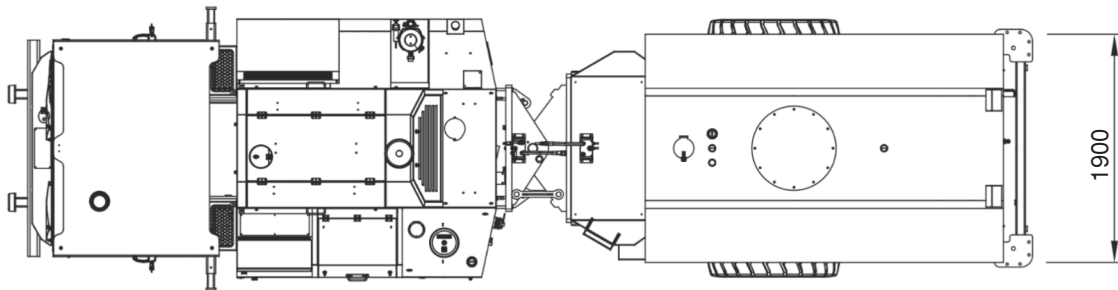
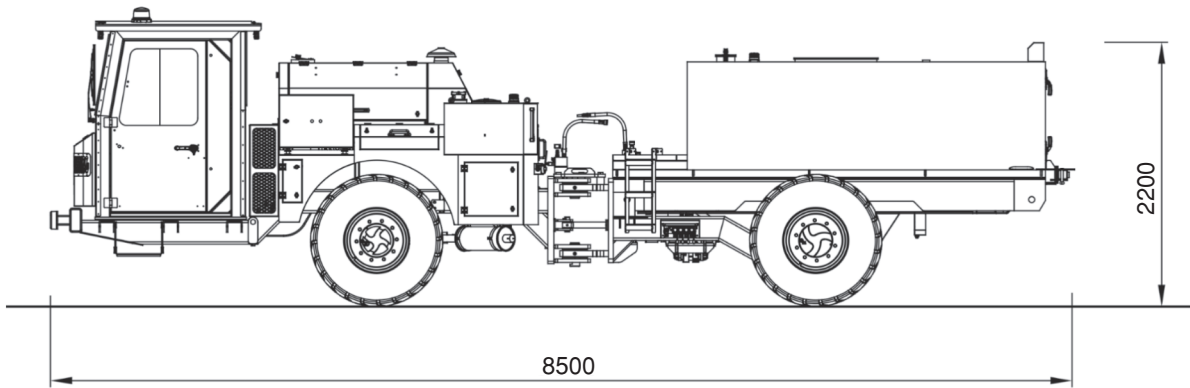

Load Carrying Cassette

